

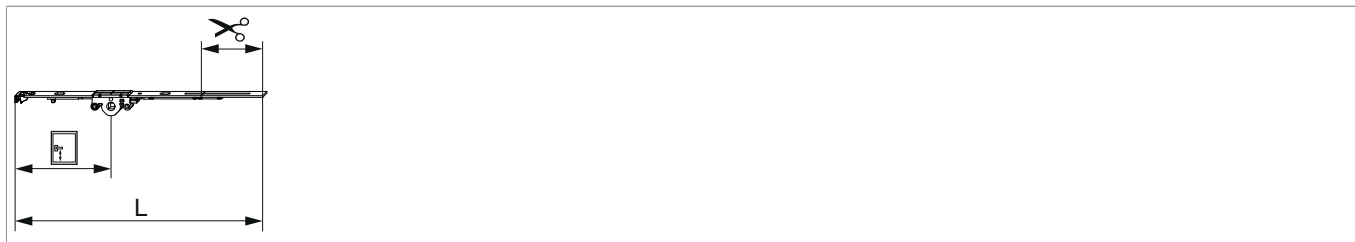

## 201730 - Cremonese A-B Multi Matic 430 E15 fix HBB 360-430 HM125 argento

### Disegni tecnici



			<b>L</b>							<b>Nº</b>
argento		430	361,5	15	125	360 - 430	116,5	-	20	201730 <sup>1)</sup>

<sup>1)</sup> Per l'avvitamento del frontale usare il fermo per frontale (cod. 213287)

### Tabella posizionamento viti

<b>Nº</b>		1	2	3	4	5	6	7	8	9	10	11	12	13	14
201730	1	18,5													

### Tabella punti di chiusura

<b>Nº</b>		Z1	Z2	Z3	Z4
201730	0				

### Dime

			<b>Nº</b>
Dima forature per fori martellina MM	per punta 3mm	1	203861
Dima forature per fori martellina MM	per punta D=3 mm e D=12 mm	1	203862



201730 - Cremonese A-B Multi Matic 430 E15 fix HBB  
360-430 HM125 argento

### Quote della scatola cremonese

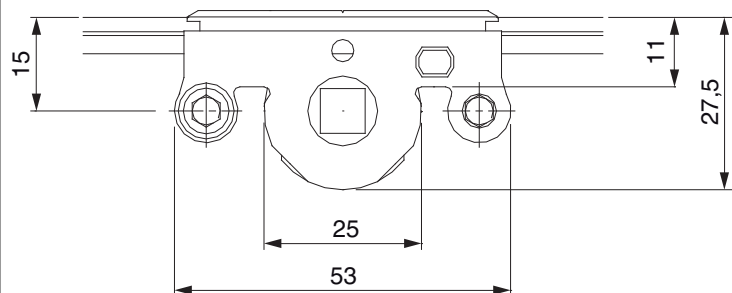

- Larghezza fresata per scatola cremonese 12 mm
- Per fissaggio maniglia utilizzare viti SPAX Ø 5 mm o viti M5.

### Schema di fresata

per PVC e alluminio

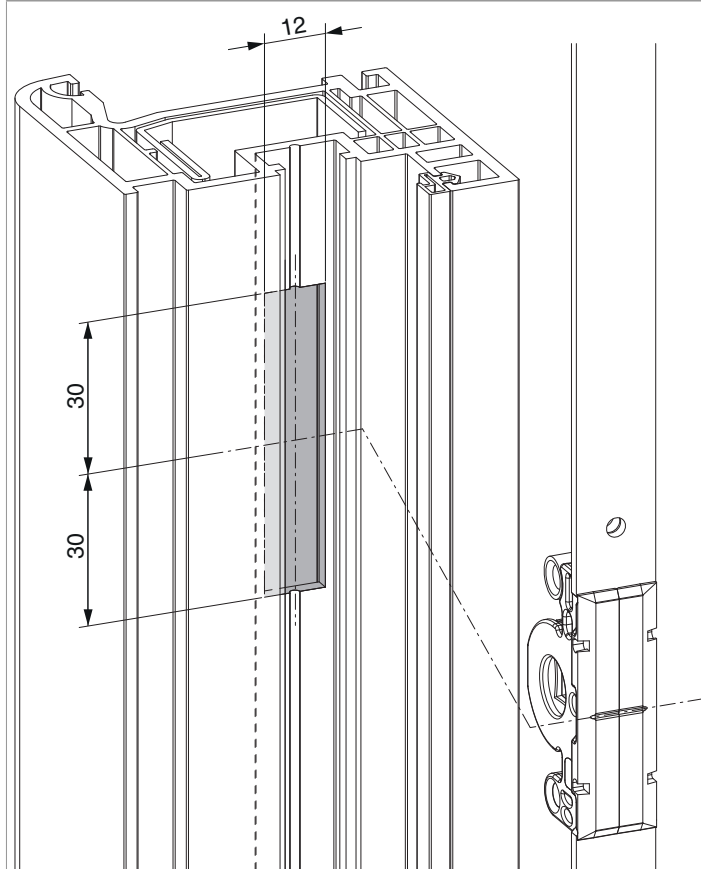



## Schema di foratura

Per serramenti in legno

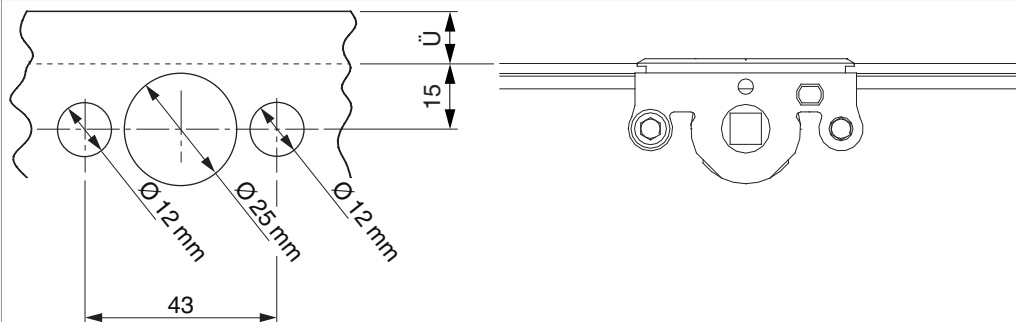

Per serramenti in PVC e alluminio

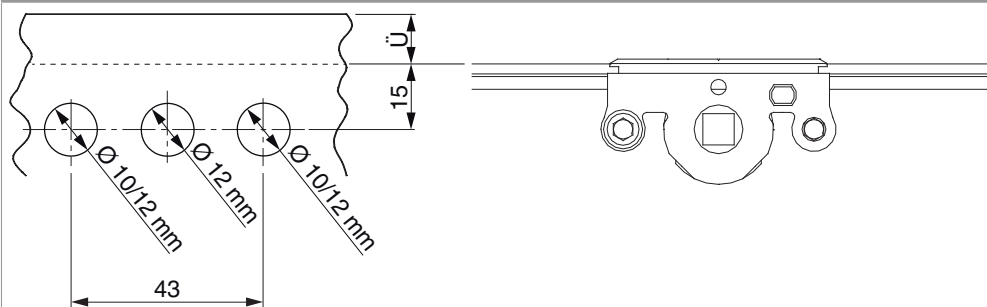



## Posizionamento scontri alza anta

Scontro alza-anta A4 / senza scrocco porta

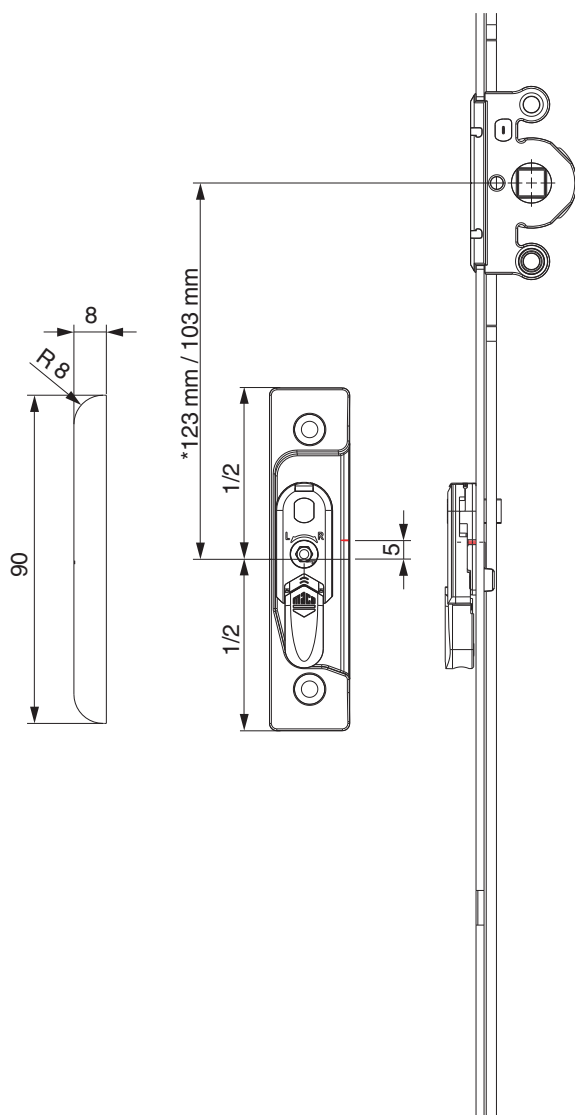

\* con cremonesi grandezza 660



201730 - Cremonese A-B Multi Matic 430 E15 fix HBB  
360-430 HM125 argento

Scontro alza-anta A4 / con scrocco porta

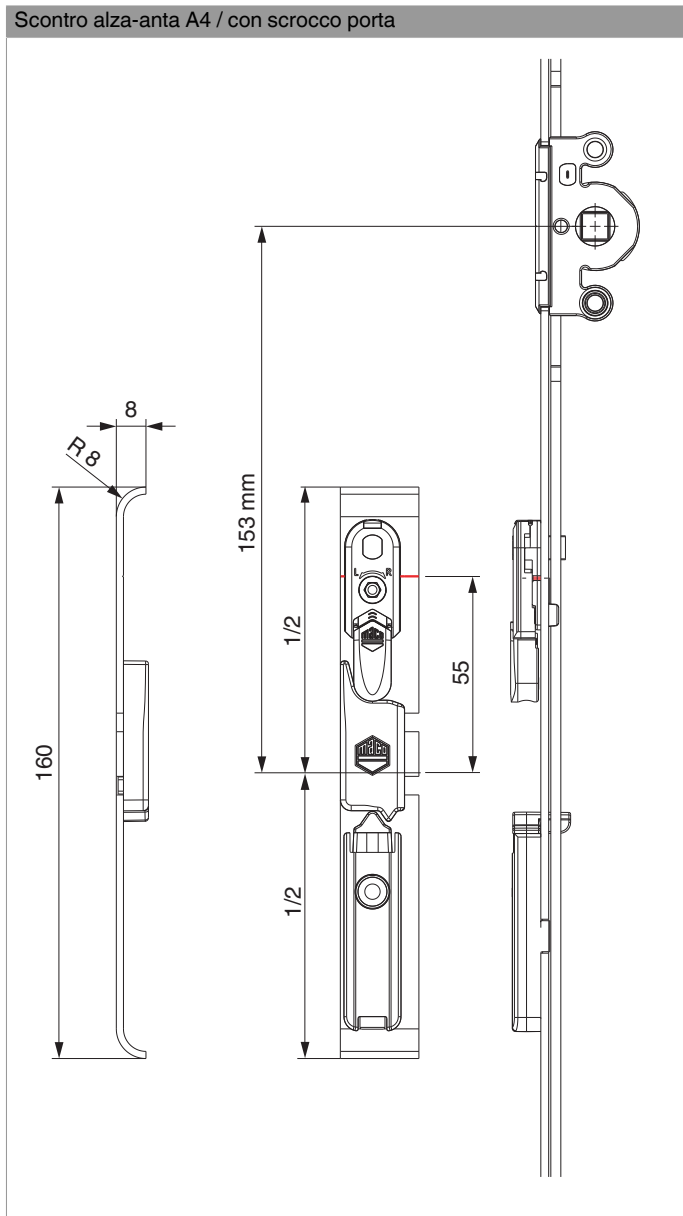



201730 - Cremonese A-B Multi Matic 430 E15 fix HBB  
360-430 HM125 argento

A12

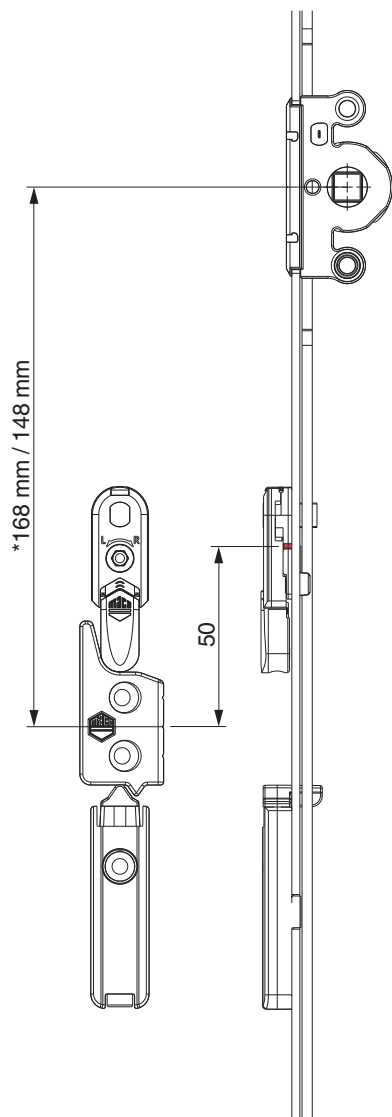

\* con cremonesi grandezza 660

## Schema di tranciatura

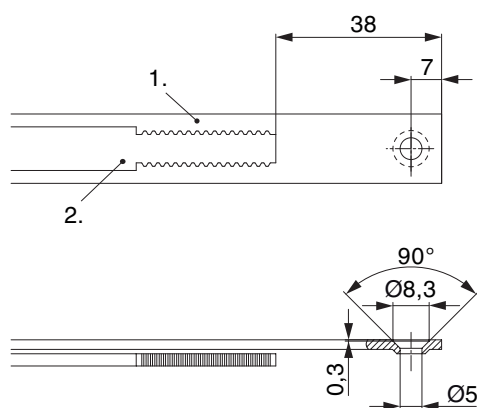

• Consigliamo di trattare il taglio dei componenti TRICOAT-PLUS con la vernice di ritocco TRICOAT-PLUS (cod. 358440).

- 1. Frontale
- 2. Asta mobile

## Oscillazione e regolazione in altezza dell'alza anta

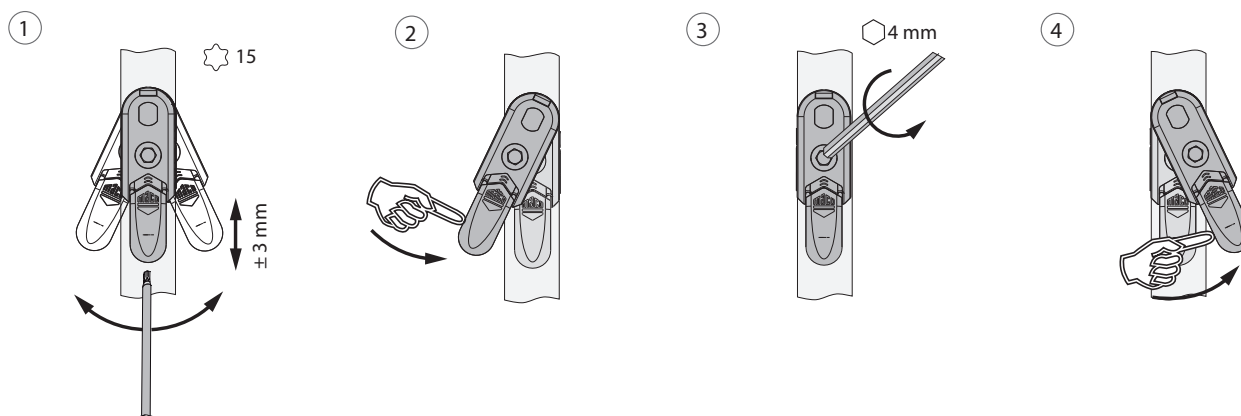

- 1. Oscillazione e regolazione in altezza dell'alza anta
- 2. Azzeramento dell'alza anta
- 3. Fissaggi centrali del dispositivo alza anta.
- 4. Orientare il dispositivo alza anta.

## Collegamento a clips

Agganciare collegamenta a clips

①

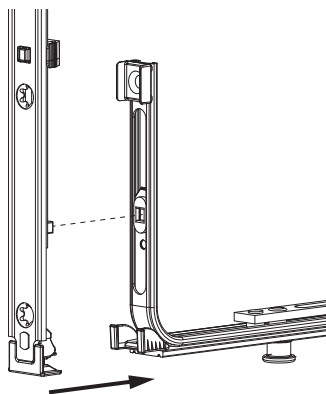

②

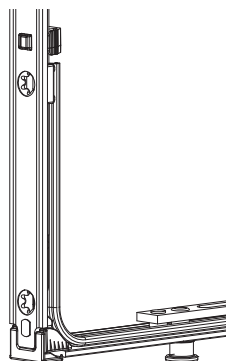

Sganciare collegamento clips

①

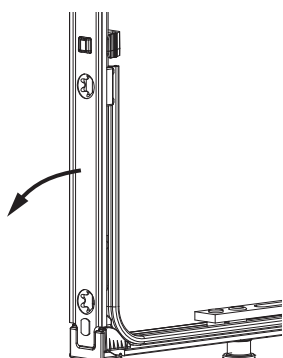

②

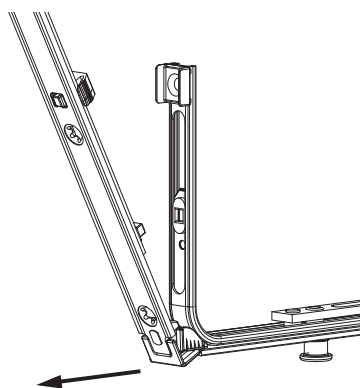

③

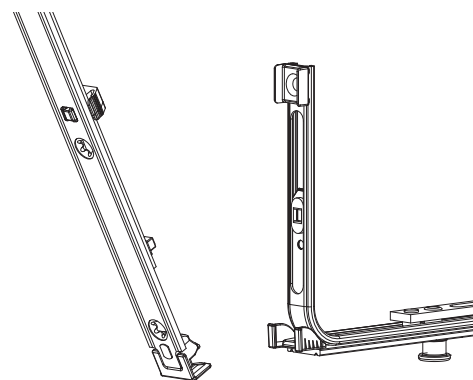



## Collegamento scarpetta dentata

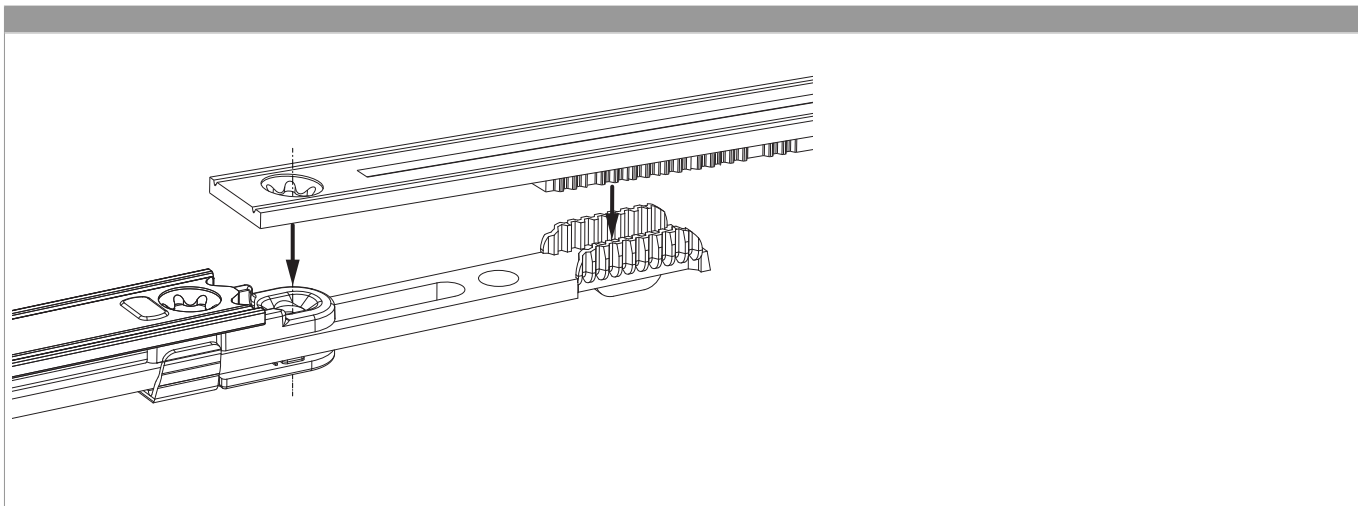

## Sequenza di avvitamento

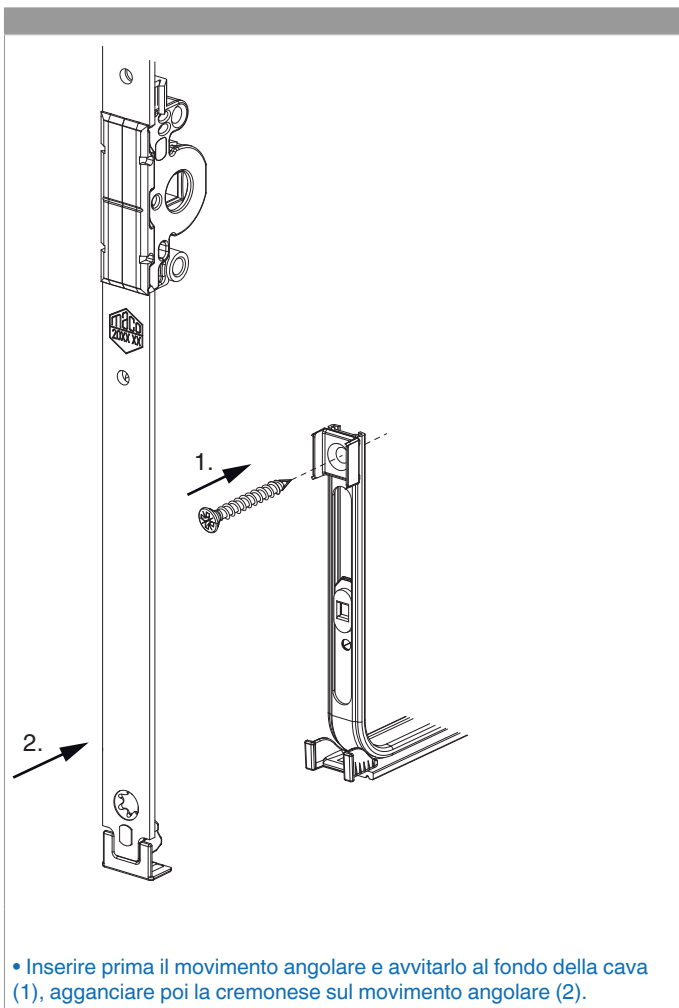



## Regolazione pressione

Fungo e nottolino

