

General Tolerances EN 22768-1 (ISO 2768-1)

Class	0,5 - 3mm	> 3 - 6mm	> 6 - 30mm	> 30 - 120mm	> 120 - 400mm
m	±0,1	±0,1	±0,2	±0,3	±0,5
c	±0,2	±0,3	±0,5	±0,8	±1,2

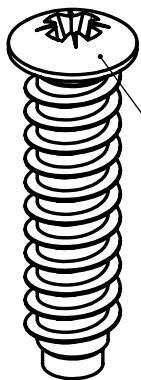
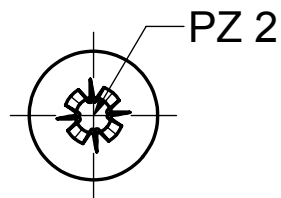
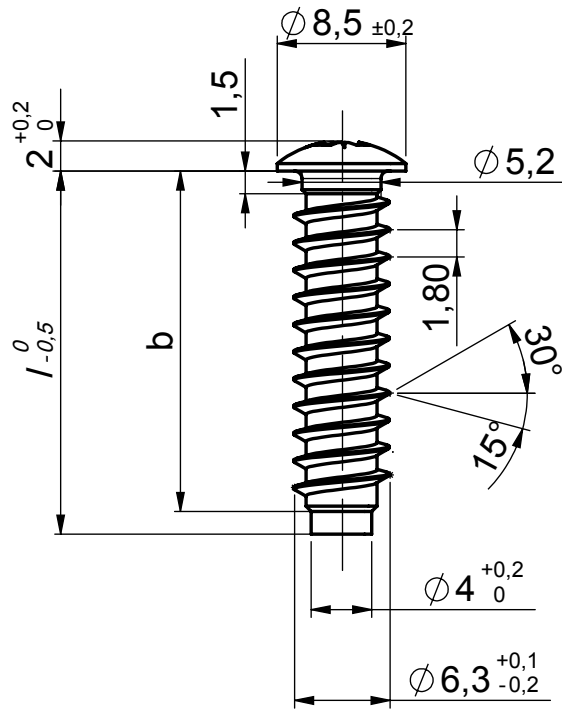

X Ray measuring point

l	b	Indicaz.
8	7,5	008
9	7,5	009
10	9,5	010
11	9,5	011
11,5	9,5	11M
12	11,5	012
13	11,5	013
14	13	014
14,5	13	14M
15	13	015
16	14,5	016
18	17,5	018
19	17,5	019
24	22,5	024

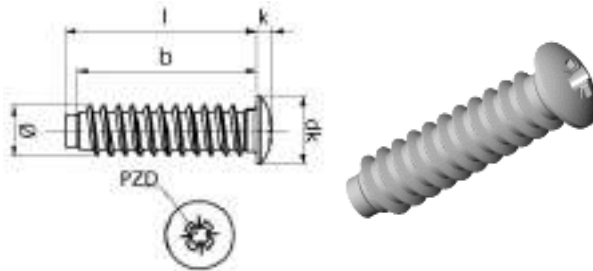

article	b	diam	dk	k	l	pzd	pilothole
422A663009	7,5	6,3	8,5	2	9	2	5
422A663010	9,5	6,3	8,5	2	10	2	5
422A663011	9,5	6,3	8,5	2	11	2	5
422A663013	11,5	6,3	8,5	2	13	2	5
422A663014	13	6,3	8,5	2	14	2	5
422A663016	14,5	6,3	8,5	2	16	2	5