

3 ali

Pesanti



Tabella quote di riferimento

Quote	Altezza cerniera		
	140	170	200
Hp	146	175	205
H	139	168	198
H1	62	75	89
H2	36	44	52
I	14,5	15	17
L	6	6	6
Ø	18	19,5	21
Øp	11,8	13	14

Specifiche d'ordine

Materiale	Articolo
ACCIAIO	E00201.14.XX
	E00201.17.XX
	E00201.20.XX

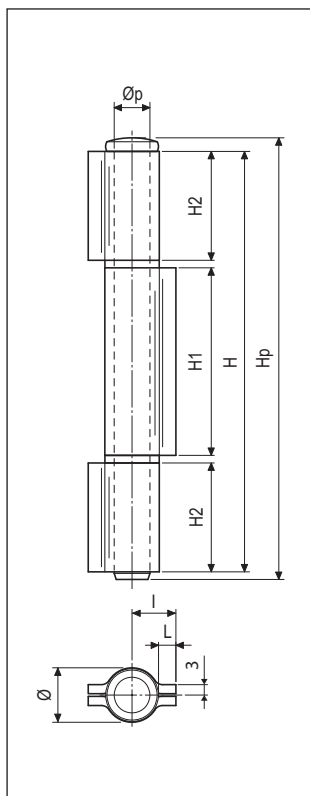
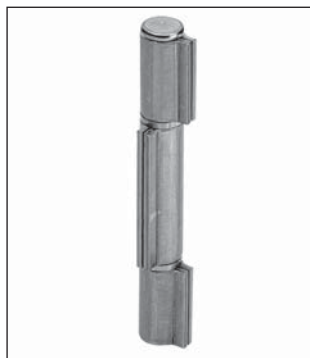
Normali



Tabella quote di riferimento

Quote	Altezza cerniera			
	80	100	120	140
Hp	81	102	121,5	145
H	77,5	99	116,5	139
H1	37,5	48	58	68
H2	18	23,5	27	33
I	11	11	12,5	13,5
L	5	4,5	5	5,5
Ø	12	13	15	16
Øp	7,9	9	10	11
S	2	2	2,5	2,5

Specifiche d'ordine

Materiale	Articolo
ACCIAIO	E00205.08.XX
	E00205.10.XX
	E00205.12.XX
	E00205.14.XX

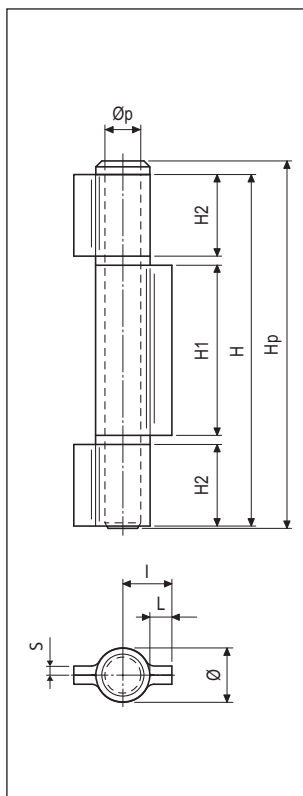
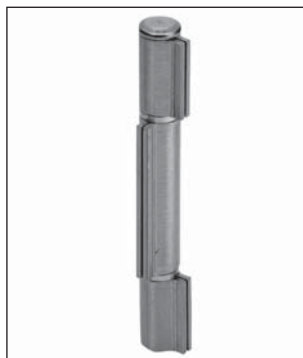
NB. Riferirsi al listino in vigore per verificare la disponibilità delle finiture.