

0506

506
507

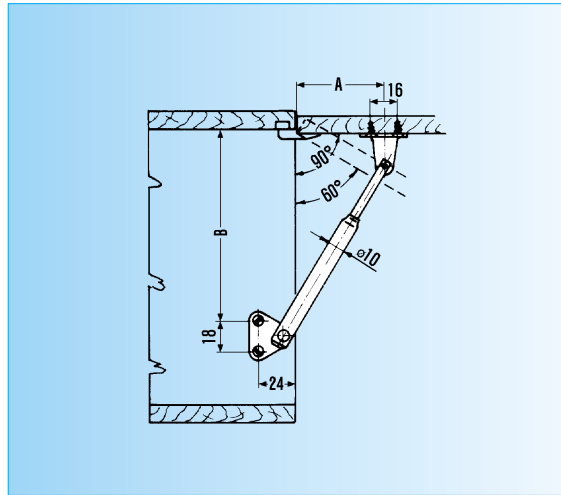

Art.	0506 mm 150	506 mm 200	507 mm 250
	60°	60°	60°
A mm	85	115	150
B mm	155	235	300
	90°	90°	90°
A mm	50	70	85
B mm	120	190	245

Art. 0506 mm 150
Cod. 4.0010 4.0030 4.0050 4.0070 4.0330 4.0350 4.0365

Art. 506 mm 200
Cod. 4.0090 4.0110 4.0130 4.0150 4.0370 4.0390 4.0405

Art. 507 mm 250
Cod. 4.0170 4.0190 4.0210 4.0230 4.0410 4.0430 4.0445
50 50 50 50 50 50 50

Acciaio ottonato • Brass-plated steel							
Acciaio bronzato • Bronze-plated steel							
Acciaio zincocromato • Zinc chromium-plated steel							
Ottone • Brass							
Ottone zincocromato • Zinc chromium-plated brass							
Ottone nichelato • Nickel-plated brass							
Ottone bronzato • Bronze-plated brass							

508

509

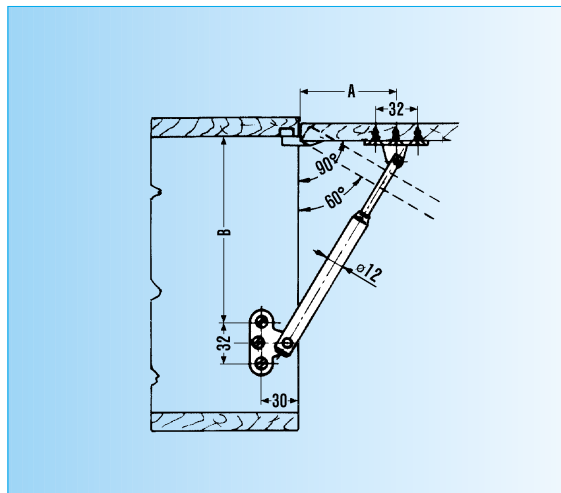

Art.	508 mm 200	509 mm 250
	60°	60°
A mm	120	130
B mm	215	280
	90°	90°
A mm	80	90
B mm	180	225

Art. 508 mm 200
Cod. 4.0250 4.0260 4.0270 4.0280 4.0450 4.0460 4.0470

Art. 509 mm 250
Cod. 4.0290 4.0300 4.0310 4.0320 4.0480 4.0490 4.0500
25 25 25 25 25 25 25

Acciaio ottonato • Brass-plated steel							
Acciaio bronzato • Bronze-plated steel							
Acciaio zincocromato • Zinc chromium-plated steel							
Ottone • Brass							
Ottone zincocromato • Zinc chromium-plated brass							
Ottone nichelato • Nickel-plated brass							
Ottone bronzato • Bronze-plated brass							