

D3DF-16-004

Dynamic 3DF

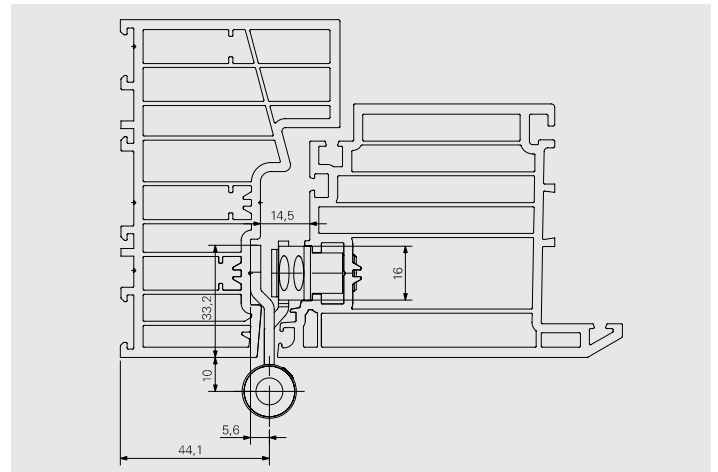
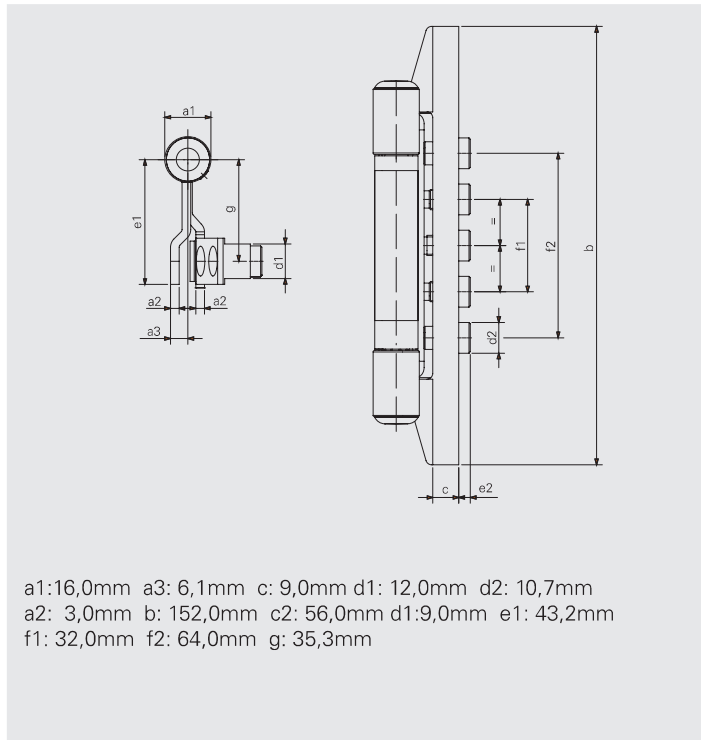

Load capacity with 2 hinges

100 kg

Raw Material

Steel
Zamak

Surface treatment

Zinc coated min 5 μ + Polyester min 100/120 μ (Powder coated)

Corrosion resistance in accordance to standard UNI EN 1670

min. 1000 hours (class 5)

Designation according to standards EN 1935

3	7	4	0	1	*	0	11
---	---	---	---	---	---	---	----

* see corrosion resistance